

# General Installation Instructions for Valves and Gates

Thank you for your purchase of a Lorenz valve. We appreciate your business! Please read this installation manual and follow recommended safety precautions.

---

Read thoroughly and contact Lorenz if you have any questions.

Canada 1-800-263-1942 USA 1-800-263-7782

**IMPORTANT – DISCONNECT & DE-ENERGIZE ALL ELECTRICAL AND COMPRESSED AIR CONNECTIONS TO ANY VALVE PRIOR TO INSTALLATION OR SERVICE**

**Caution:** Please follow your prescribed safety policy during installation. Use extreme caution when handling these valves. Do not energize until all proper installation steps have been completed and all guarding is in place. Lock out all sources of energy & air before servicing or inspection and during installation.

## **SAFETY**

Before attempting installation or before connecting electricity or air supply, please review and familiarize yourself with the operation of the Lorenz valve or gate. Be aware of any sliding blades and moving parts which could cause injury if the valve or gate is handled incorrectly. Keep all body parts clear of these potential hazard areas.

Before actuating, ensure all personnel and equipment are clear of any moving parts. Pay attention to any warning labels on the valve or gate. Do not operate without all supplied guarding in place. Keep hands clear of any moving parts. Please contact Lorenz if you have any questions regarding the safe handling and installation of your valve or gate.

## **UNPACKING AND INSPECTION**

Please carefully examine the box or crate for damage by the carrier during shipping. Immediately report any damage or missing boxes/ crates to the delivering carrier. Lorenz is not responsible for damages caused in transit, but can assist you in launching a claim with the carrier. Please notify Lorenz immediately of any damages or shortages.

## **STORAGE AND HANDLING**

All valves should be stored in an enclosed, clean, dry area, free from excess humidity temperatures or moisture. All valves should be stored with all openings covered to prevent foreign matter from entering the valve including all solenoids and electrical connections and compressed air lines.

## **ELECTRICAL REQUIREMENTS**

Please ensure all electrical connections are to local codes and done by qualified personnel. An electrical disconnect box must be provided for electrical actuators with a mechanical lock out in the off position. Valves and Gates equipped with Solenoid Valves and Limit Switches will require power supply. Please check Solenoid Valve and Limit Switch specification in Appendix for requirements.

## MECHANICAL CONNECTIONS AND MOUNTING

### *Flange Connections*

Check to make sure flange bolt holes line up and that the sizes match. Ensure mating flange is clear of old sealing/ gasket material, corrosion and other debris. Mating flanges should be flat and straight. Do not drill into flange on valve as this can damage the valve and will void the warranty.

Use grade 5 bolts & nuts or better along with washers and lock nuts to make the connection. Do not over-tighten nuts (**NOTE: BBH (Blind Bolt Hole) connections – Do not bottom out the bolt into the valve as this will damage the valve and void the warranty.**)

Please take into consideration flange thickness complete with washers and gaskets when determining bolt length. Flange gaskets should be used with BBH and SB flange options.

With compression coupling connections, valves must be supported on either side. Allow for expansion or contraction of conveying line as well.

### *Support Requirements*

All incoming / outgoing conveying lines must be supported as per local codes. All valves must be properly supported prevent binding and damage (See appropriate section below). Failure to support any valves or the conveying lines will void the warranty. Avoid supporting conveying lines or other equipment other than factory supplied accessories from the valve or gate body.

Valves and Gates should only be lifted from the main body. Do not lift valves from the actuator as this could damage the actuator. Lorenz is not responsible for any damage caused by improper lifting during unpacking and installation.

Valves or Gates with Electrical Actuators may require additional support due to the weight of the Electrical Actuator.

### *Slide Gates, Diverter Gates, Aggregate Gates, Slide Flex Gates, Roller Gates Mounting*

It is important to ensure that the gate body and actuator are properly supported to maintain an accurate alignment of the actuator and mechanism for proper operation of the gate.

### *Sealed/Unsealed Gravity Diverters, Aggregate Diverters Mounting*

These valves generally are supported by the flange or tube connections and do not generally require additional support for the actuator to ensure correct operation. Larger size diverters may require additional structural support and must be provided for before installation. Please ensure connecting lines and equipment is supported as per local code and is sufficient to carry the weight of the Diverter.

## PNEUMATIC REQUIREMENTS

A vented ball valve should be installed within 12" of air cylinder as an Air Supply Shut off. Vented ball valves allow the air pressure to escape from air cylinder preventing un-expected closure. (Regular ball valves trap the air in and are not recommended)

Compressed air lines should be at least the same inside diameter as the ports on the factory supplied air control valve to provide the proper valve actuation. Factory supplied air controls are sized for proper valve performance. Inadequately sized controls will affect performance of the valve.

There must be **a minimum of 80 PSIG compressed air pressure at the air cylinder** to ensure proper operation. Maximum air pressure is 150 PSIG. Clean and dry compressed air is required to insure proper operation of the air cylinder. High moisture at low temperatures can cause the air control valves and the air cylinder to freeze.

All valves with “Air Purge” feature must be set at 1-2 PSIG greater than the conveying pressure (15 psig maximum) to create a positive pressure within the valve body. Air purge pressure can be adjusted by pressure regulator installed on the valve.

System Differential Pressure – The pressure differential ratings for Lorenz valves are:

- 1) Roller Gates, Maintenance Gates, Aggregate Gates, Gravity Diverters and Aggregate Diverters are limited to applications which contain NO Air Pressure
- 2) Diverter Valves, Slide Gates, Slide Flex, Discharge Valve is limited to application under 15 psig

Warranty is void if valve is operated beyond rated limits. Please consult technical support for information.

### **ENVIRONMENT**

All valves are designed for use in most indoor applications. Valves with electric and/or air controls that are subject to wash down conditions should be protected as per local codes. Do not wash down any valve with gate in the closed position as it could affect the performance of the valves and seals. Do not use any harsh or caustic solutions during wash down as they could damage the seals and affect the performance of the valve. Valves equipped with washdown capable components can be washed down with gate in the open position and water temperature should not exceed 82C (180F). Use of valve in environments exceeding the specified temperature rating will damage the seals and void the warranty. **Do not weld or use open flame on or near the valve.** The seals will be damaged and void the warranty.

For proper operation of the valve air controls, switches and valve should be protected from rain and snow. A protective weather shield is recommended. Moisture & high humidity can damage the valve by causing the seals to swell; a wash down modification is required for any valve in this situation.

## WIRING DIAGRAMS

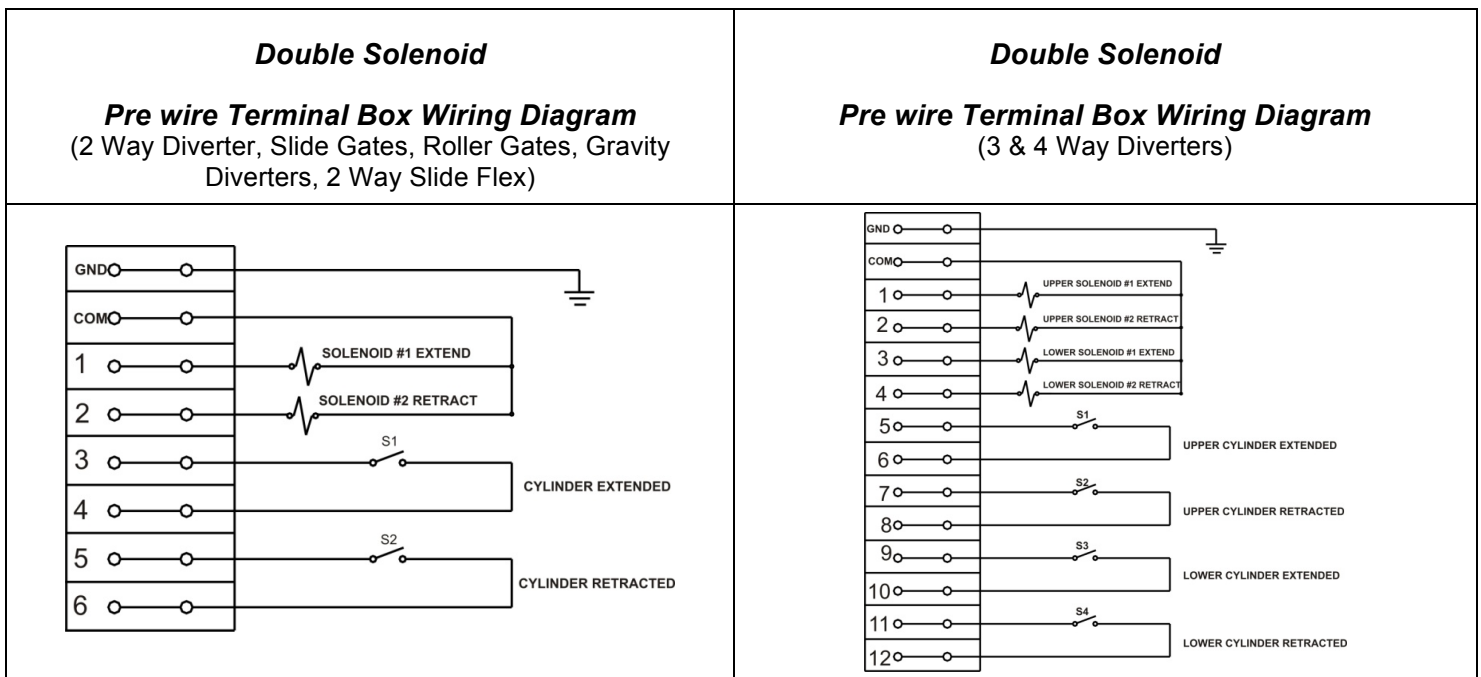
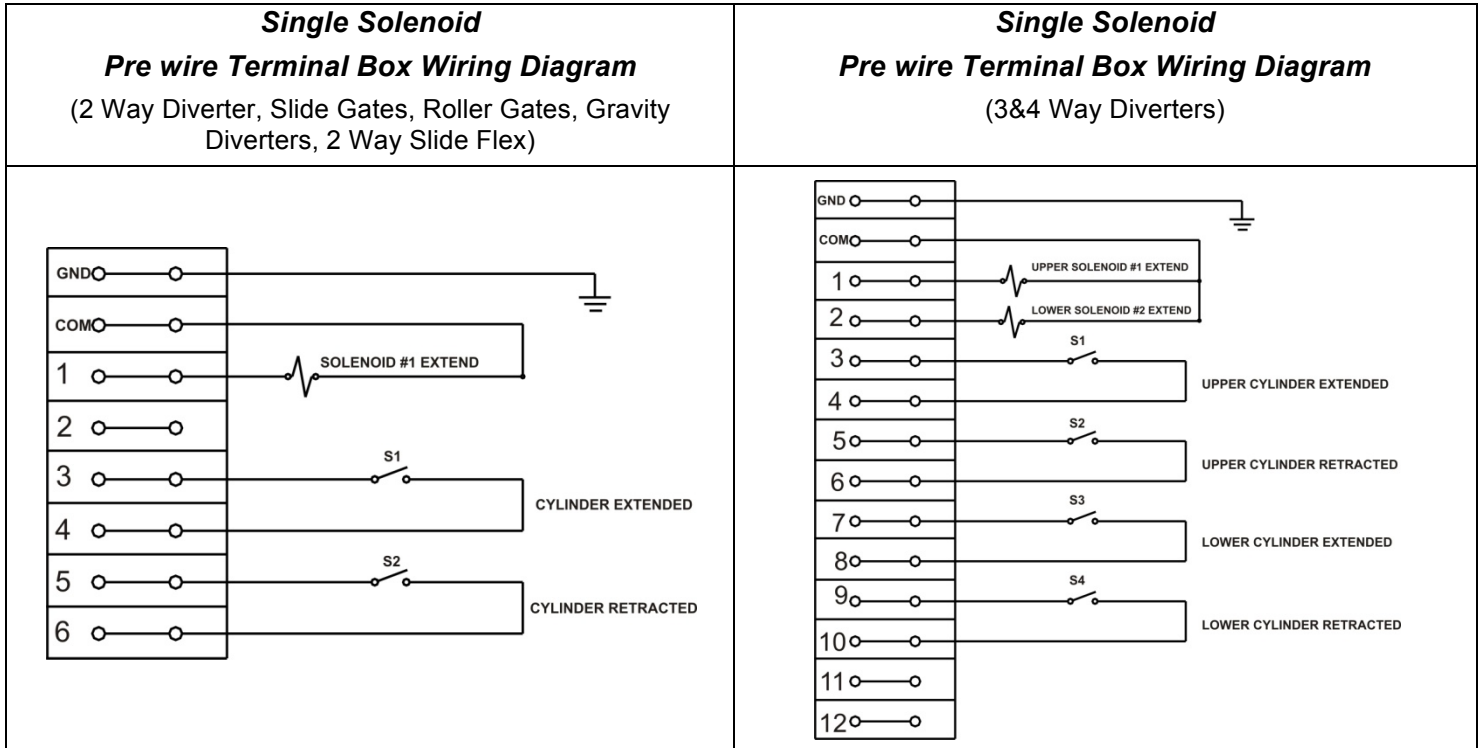

**POSITION SWITCHES**

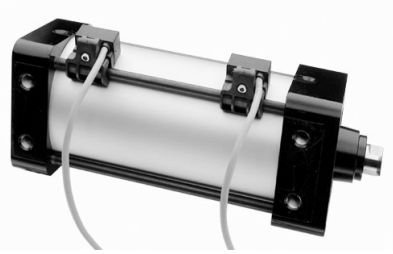

	<i>SW-R-004</i>	<i>SW-RX-001</i>
Description	Reed Switch, MOV, LED Light, 2 Wire	Reed Switch, MOV, LED, 3 Wire
Function	Normally Open SPST	Normally Open TRIAC output
Switching Voltage	5 – 240 VDC/VAC 50/60 Hz	24 – 240 VAC 50/60 Hz
Switching Current	1 Amp Max, .005 Amp Min	4 Amp Max, 50 Amp Inrush, .005Amp Min
Switching Power	30 watts Max.	100 watts Max.
Switch Speed	0.6ms operate, 0.05ms release	0.6ms operate, 0.05ms release
Voltage Drop	3 volts	1 volt
Temperature Range	-20°C to +80°C (-4°F to + 176°F)	-20°C to +80°C (-4°F to + 176°F)
Lead Length	9 feet	9 feet
Usage notes	For PLC Application	Will light control panel
Wiring Diagram		
	A   Red	A   Red
	B   Black	B   Black
		C   White

Note: Usage above maximum ratings or incorrect wiring connections will result in damage to switch.

**POSITION SWITCH TROUBLE SHOOTING NOTES**

Problem	Solution
Reed Switch works but LED does not light	<ol style="list-style-type: none"> <li>1. Check current draw of load. It must be &gt; 5 mA for LED to light.</li> <li>2. Check polarity: Refer to wiring diagram if using DC power supply</li> </ol>
Reed switch sticks in closed position.	<ol style="list-style-type: none"> <li>1. Check current draw, power/VA and voltage of load and compare with specs of the appropriate model sensor. These cannot be exceeded.</li> <li>2. Voltage/Current spikes may be excessive for your particular load. External transient suppression may be required.</li> <li>3. Long wire runs (greater than 25') can cause capacitance build-up and sticking will result. Consult factory for solution.</li> </ol>
Current or voltage leakage when reed switch is off.	<ol style="list-style-type: none"> <li>1. Check current, power/VA and voltage rating of load and compare with specs of appropriate model sensor. Those cannot be exceeded.</li> <li>2. Reed element was damaged. Consult factory.</li> </ol>
Reed switch will not turn on.	<ol style="list-style-type: none"> <li>1. Check magnet strength on surface of sensor. It must be &gt;85 Gauss.</li> <li>2. Switch is damaged. Consult factory.</li> <li>3. Check for proper wiring.</li> </ol>
Reed switch turns on more than once as magnet passes beneath it.	<ol style="list-style-type: none"> <li>1. Check for proper magnet polarity. The poles must be parallel to the switch as shown in the wiring diagram.</li> <li>2. Check for dead spots on the magnet if polarity is correct.</li> </ol>

## **WARRANTY**

*Any modifications to any valve other than recommended maintenance voids the warranty. Please contact Lorenz if you have any questions regarding maintenance or troubleshooting and before attempting any repairs.*

Lorenz warrants to the original buyer only that all products or parts sold by Lorenz shall be free of defects in materials and workmanship for a period of one (1) year from the date of shipment, when used according to Lorenz recommended usages. This warranty is strictly limited to repair or replacement of defective parts, provided those products are returned to Lorenz prepaid. Labour and materials for any downtime/repair/replacement is not covered. This warranty shall be considered void if such products are misused, improperly installed, improperly stored, operated beyond rate limitations, damaged, neglected, altered/changed/repared or modified by anyone other than Lorenz or designate. Lorenz assumes no responsibility for any emissions from our valves.

All special order products or material are not returnable. No liability is assumed for consequential damages or for any labour or other expense incurred by reason of sale or use of our products, singularly or in combination with other products. To the best of our ability products will be delivered at specific times but no liability is assumed for failure to deliver because of delays or defaults occasioned directly or indirectly by fire, flood, act of God, labour trouble or shortage or any cause unavoidable beyond our reasonable contract.

Goods remain the property of the seller until payment is received in full and purchaser acknowledges in full that this is a security agreement and a document to this effect may be registered according to the local and applicable legislation or there shall be a charge for the full purchase price on the goods. All special order products or material are not returnable.